

GENERAL DETAILS

| | |
|-----------------------|---------------------|
| INSTALACIÓN | recessed with frame |
| COLOR EXT-INT | Black-White |
| DIRECCIÓN DE LA LUZ | Fixed |
| ÁNGULO DEL HAZ DE LUZ | 30º |
| INT-EXT ESTANQUEIDAD | IP20/23 |
| MATERIAL | Aluminum |
| RESISTENCIA MECÁNICA | IK 6 |
| USO | Indoor |
| GARANTÍA | 5 years |

ELECTRICAL DETAILS

| | |
|----------------------------------|-----------|
| FUENTE DE LUZ | LED |
| POTENCIA | 10W |
| TEMPERATURA DE COLOR | 2700K |
| FLUJO LUMÍNICO | 835 Lm |
| EFICIENCIA LUMÍNICA | 70 Lm/W |
| DIMABLE | Push |
| DRIVER | Remote |
| CLASE DE SEGURIDAD | II |
| ÍNDICE DE REPRODUCCIÓN CROMÁTICA | CRI>90 |
| TENSIÓN | 220-240 V |
| CORRIENTE | 700 mA |
| VIDA UTIL | 50.000 h |

GENERAL DIMENSIONS

| | |
|-------------------------|------------------|
| DIMENSIÓN | .04 (147x45mm) |
| AGUJERO DE CORTE | 140x37 mm |
| DIMENSIONES DE EMBALAJE | 190 × 80 × 85 mm |
| PESO NETO | 32 |

*Please might expect a max. 15% figure reduction in finishes other than white

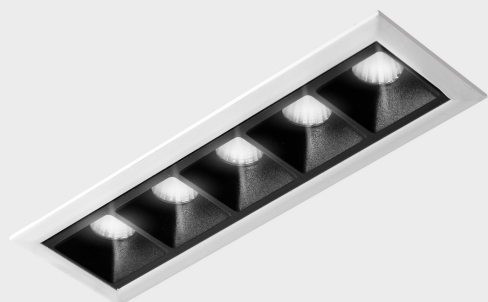

nses

K51300.04.RF.WH-BK.30.ST.9.27.PU

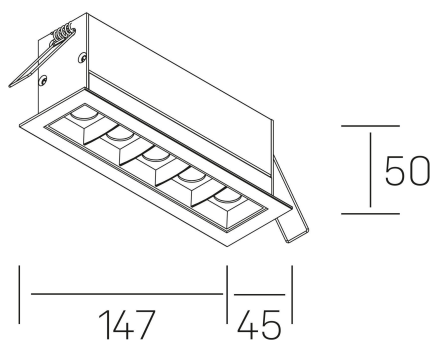

147

45

50